



Exp 3000/3000R

Your P/PM program is only as good as the tools that you use. Develop a total system understanding through visualizing true motor conditions and knowing where potential problems exist.

For over 40 years, Baker Instrument Company, an SKF Group Company has pioneered the development and manufacture of diagnostic test equipment for all types of electrical rotating machinery. Following a complete line of comprehensive test equipment is the Explorer. Developed for in-service monitoring of power circuit issues, overall motor health, load and performance, it gives the user a comprehensive look at overall motor integrity.

This instrument accomplishes fully remote monitoring from the Motor Control Center (MCC), is a non-hazardous low-voltage battery operated unit, and is highly portable and durable for use in even the tightest and most rugged circumstances.

Continuing Innovation

With the EXP3000/3000R, Baker Instrument Company, an SKF Group Company continues to pioneer new breakthroughs that demonstrate an ongoing commitment to quality, reliability, and competitive advantage. This in-service motor analyzer takes the next step in providing complete P/PM programs. It provides **root-cause analysis** through the separation of

mechanical and electrical issues. The EXP3000/3000R was engineered to pinpoint challenges (**voltage source,**



VFD, motor, load) your rotating machinery face. This self-contained portable instrument is computer driven with proven engineering, allowing all testing to be accomplished directly from the MCC or from the EP connection.

Comprehensive Motor Analysis

As the latest innovation in plant management, the EXP3000/3000R performs seven major functions in a complete predictive maintenance program. It identifies possible power circuit problems that degrade motor health, examines overall motor power conditions, monitors the load and observes motor performance plus estimating energy savings.

No other motor monitor on the market today gives you the wide variety of capabilities that the EXP3000/3000R offers. It is programmed to supply information on voltage level, voltage balance, harmonic and total distortion, rotor cage condition, motor efficiency, effective service factor, overcurrent, operating condition, torque ripple, load history among others. This wide range of tests lets you explore the true condition of motor integrity and the conditions related to motor performance.



an SKG Group Company

Advanced Data Collection

Once testing is completed, results can be saved and stored for each individual motor. This type of documentation is critical for any predictive maintenance program. It allows the recalling of previous information for true trending capabilities. With the EXP3000/ EXP3000R, test results are collected, stored, recalled, and managed using standard MS Access relational database file formats. Reports can be generated quickly and easily through the main print console, allowing operators visual confirmation of motor integrity information.

Ease of Data Organization

Collected data is only valuable if it is kept in a manner that is useful to everyone concerned. The EXP3000/ 3000R's software and data transfer package enables you to create multiple databases to organize collected data to your specifications, easing communication channels with co-workers and clients.

The Power Behind On-Line Monitoring

The EXP3000/3000R completes the global approach to motor testing by Baker Instrument Company, an SKF Group Company. It renders information on degradation of motor performance and the effects of overheating on motor operation. Survey plant wide efficiency with an EXP3000/3000R and determine load **mismatches**, **oscillating load**, and **transient peak energy**. It's on-line capabilities allow accurate assessment of operating load conditions over time. Results are immediate and show operating efficiencies allowing you to determine the true cost of wasted energy.

Test Domains

Power Quality

This testing domain identifies non-optimal power quality problems, which cause additional undue stress to the motor. The voltage level, voltage balance, harmonic distortion, total distortion, power and harmonics tests flag frequent problems. These can consist of wrong settings on supply transformer's taps, poorly distributed single phase loads, overloading (saturating) supply transformers, excessive VFDs on low voltage busses, excessive non-harmonic frequencies on a VFD, missing line-inductors on VFD applications and missing or open

	A	B	C	Ave / Sum
kW	0.1	0.2	0.2	0.5
kVAr	0.2	0.2	0.2	0.6
kVA	0.2	0.3	0.2	0.7
pf	0.64	0.64	0.64	0.64
V	133.5	135.5	134.5	203.0
I	1.7	1.9	1.8	1.8
THDv %	0.1	0.1	0.1	0.1
THDi %	0.1	0.1	0.1	0.1
c.l.v	1.42	1.42	1.43	1.43
c.l.i	1.43	1.43	1.42	1.43
NEMA Voltage Unbalance (%)				0.74
NEMA Current Unbalance (%)				5.56
Average Fundamental Frequency				50.0

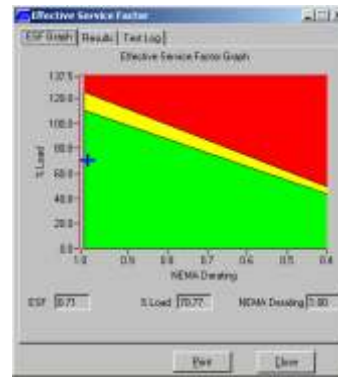

Condition, Efficiency, and calculates Payback Period. Common problems found in this area included: Thermal overloading of the motor, recognizes the deterioration of the machine among other items that are directly related to the motors health and the energy wasted in it inefficiencies.

Current

This set of tests identifies problems within the entire machine system. These tests include: Overcurrent, Current Unbalance, and Sum of Currents. These tests look at the health of the entire system and describe a problem within this system as it is related to current. This domain identifies problems, however the root cause may not be apparent.

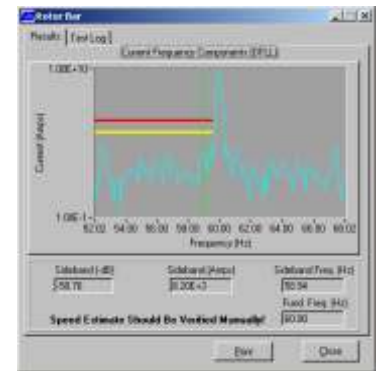

Spectrum

This domain has the rotor bar test along with V/I Spectrum, Demodulated Spectrum, and Harmonics. This domain shows the current and voltage relationships with regards to frequency. It will electrically find saturation problems, broken rotor bars, excessive VFD drives on low voltage busses and it can verify mechanical problems.

Torque

The Torque domain is a highly important breakthrough for Baker Instrument Company. These tests, Torque Ripple and Torque Spectrum, enable the user to find a numerous amount of problems quickly and accurately. This domain specializes in diagnosing

power factor correction capacitors.

Machine Performance

This group of tests conclusively evaluates the present operation of the motor, identifying stressful operation and its source. It looks at Effective Service Factor, Load, Operation

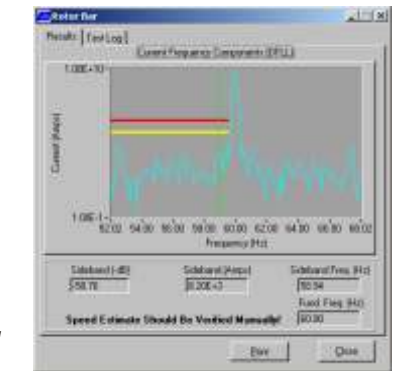

mechanical issues, shows transient overloading, finds soft-foot mechanical imbalances along with bearing problems, cavitation and many other items.

Connections

This portion of EXP3000 offers multiple additional tools, including phasor diagrams, 3 currents, 3 voltage, and harmonic bar charts, instantaneous voltage, frequency, symmetrical

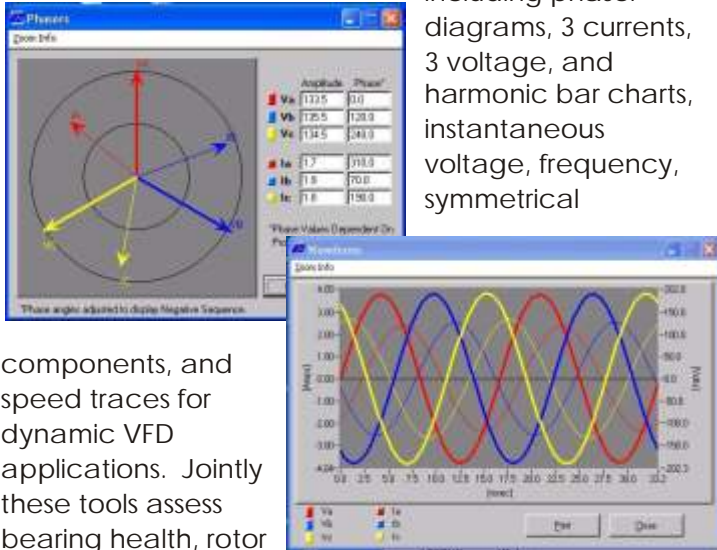

components, and speed traces for dynamic VFD applications. Jointly these tools assess bearing health, rotor unbalance, misalignment and bent shaft.

VFD Monitoring (Optional)

Baker Instrument Company, an SKF Group Company designed the EXP3000 as a comprehensive monitoring tool. Along with any three phase induction motor and generator, it will also

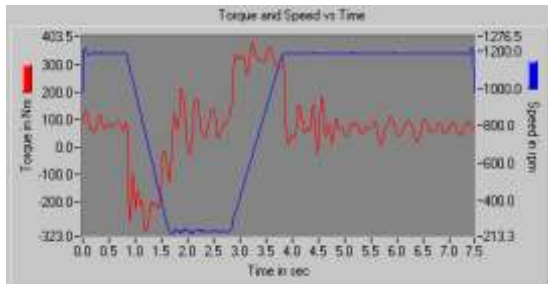

monitor the activities of Variable Frequency Drive (VFD) applications and AC servo motors. These style of drives have always created problems for the maintenance professional. For the first time comprehensive diagnosis of motor problems are facilitated even under the most demanding VFD operation. The Optional, VFD 3000 shows how frequency, speed, torque, and voltage level vary with respect to time.

Continuous Monitoring

The newest feature of the EXP3000/3000R is Continuous Monitoring. The CM3000 software enables the user to monitor upwards of 41 data points real time. This real time and continuous data gathering capability will give immediate impact in finding intermittent problems with motor such as electrical tripping. This user

customizable software enables the operator to collect real time data on whatever is deemed the most important to their operation.

This portion of the EXP3000/3000R will also act as a Power Analyzer to determine actual power quality. This tool is another innovation from Baker Instrument Company, an SKF Group Company that enables the user to further develop comprehensive predictive maintenance programs.

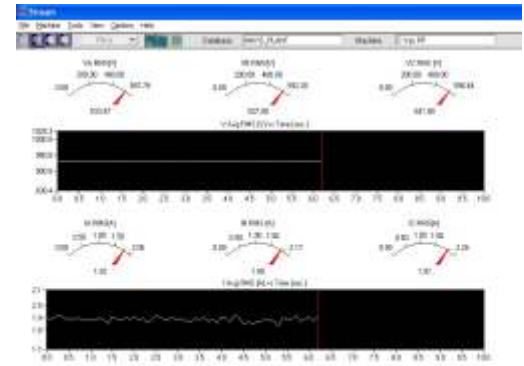

Transient Analysis

EXP3000/3000R can perform a startup transient analysis using the Transient Acquisition Tool. The traces are the rms currents and voltages of all three phases. This

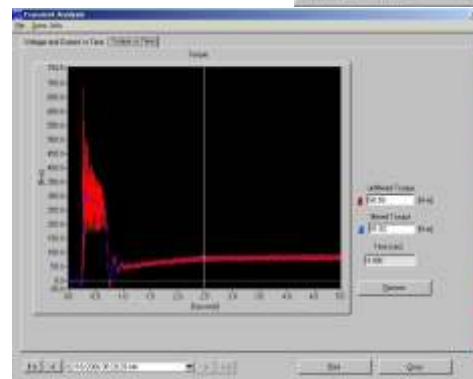
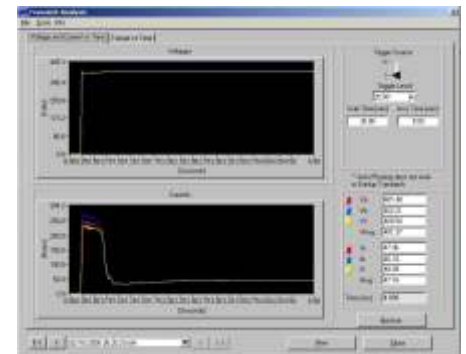

data can be zoomed, panned, and the available cursors allow readings of levels and time in the graphs. Along with this powerful analysis capability startup Torque vs. Time

can also be evaluated. These two tools allow the user to visually see the amplitude of voltage, current and torque at startup and also shows how long the startup process took for the motor. Finally, as the startup process concludes, the final level voltage, current and torque can be visualized.

The Location of EXP3000

The set of efficiency assessment, pay-back period and Motor Master+ identifies motors performing under par, and calculates the pay-back period if replaced by a new motor. The EXP3000 has consistently proven itself as "best of class" in neutral side-to-side tests compared to other efficiency estimation methods or hardware. It

has out-competed all contenders in both: accuracy of efficiency estimation and in ease of use for field environments.

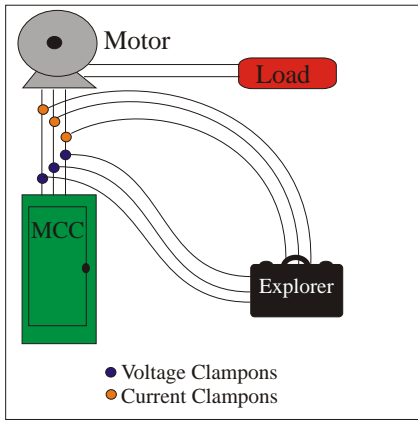

Specifications

A. Testing Capabilities

1. Voltage Unbalance
2. Voltage THD
3. Current THD
4. Harmonic Voltage Factor
5. Impedance Imbalance
6. Eccentricity
7. Rotor Bar Test
8. Negative Sequence Impedance
9. Speed Calculation
10. %Load & %Efficiency
11. Spectrum Voltage
12. Spectrum Current
13. Current Level
14. Effective Service Factor
15. Power Details
16. Continuous Acquisition
17. O-Scope
18. Auto Phasing
19. Auto Testing Including Timer Function
20. One Button Testing
21. Bearing Check
22. Mis-Alignment and Bent Shaft
23. Startup Transient Voltage
24. Startup Current

Modular Software Enhancements

The software for the EXP3000/EXP3000R is broken into modular units to create a greater mix of capabilities to the overall operation of the instrument.

VFD 3000

Shows how frequency, speed, torque and voltage level vary with respect to time, enabling identification of transient overloading of the motor by the VFD. It provides the ability to identify and repair poorly tuned speed feedback giving you the ability to see true motor operating conditions.

CM3000

Obtain information on a true real time continuous

manner. Displays all incoming information in a quick and easy to understand manner.

T3000

Obtain dramatic results and a greater degree of confidence in motor findings with conclusive evidence of problems through torque analysis. Baker Instrument Company, an SKF Group Company is the only company offering this highly unique and comprehensive look at motor reliability and health.

V3000

Vibration analysis using Haystack method.

Unit Specifications

Dimensions: 13.375" x 11.675" x 6"

Volume: 920 cubic inches

Weight: 12.5 lbs

Case: Hinged Cover "Pelican", Dust-tight Enclosure

Input Power: 100-250 VAC, 50/60 Hz Integrated Power Supply

Current Transformers Available: 0-10amp, 0-150amp, 1-1000amp, 0-3000amp (cable ct's) {All Portable}

Connections: Amphenol Military Spec Twist Type:
Voltage Current
1-Power Entry Module, 1-Portable Voltage Connections,
1-Portable Current Connection, 1-EP Port, 1-Vibration
Sensor Connection

Computer Specifications: IBM Thinkpad/Panasonic
Toughbook or equivalent.

Software Platform: Windows EX Professional (or higher)

Ports: USB2.0

Industry Standards (IEEE, NEMA, Etc.): NEMA MG-1, IEEE
519, EN61000-2-2, EN 61000-2-4, VDE 839-2-2, VDE 839-2-
4.com



Baker Instrument Company, an SKF Group Company
4812 McMurry Avenue
Fort Collins, CO 80525
970/282-1200 - 800/752-8272 - Fax 970/282-1010
www.bakerinst.com